

Quick Tips Guide to Transfer a Call and Access Voice Mail
support@covoda.com or call (877) 268-6325



How to transfer a call that is ANNOUNCED

- ➔ While on the call, press Transfer button
- ➔ Dial number of the person or extension you want to transfer call to.
- ➔ Wait for person to answer and speak with them to announce caller
- ➔ Press Transfer/Send

How to perform a blind transfer (UNANNOUNCED):

- ➔ While on the call, press Transfer button
- ➔ Press Blind
- ➔ Dial number of the person or extension you want to transfer call to
- ➔ Press Send

How to send a call directly to voicemail

- ➔ While on the call press Transfer button
- ➔ Press Blind
- ➔ Dial 00
- ➔ Dial number of the person or extension you want to transfer call to
- ➔ Press Send

How to Access voice mail:

- ➔ Press the envelope key
- ➔ Enter your password when prompted
- ➔ Follow the menu prompts to access your messages and voicemail features

The images below will appear on the back

300VXX Layout

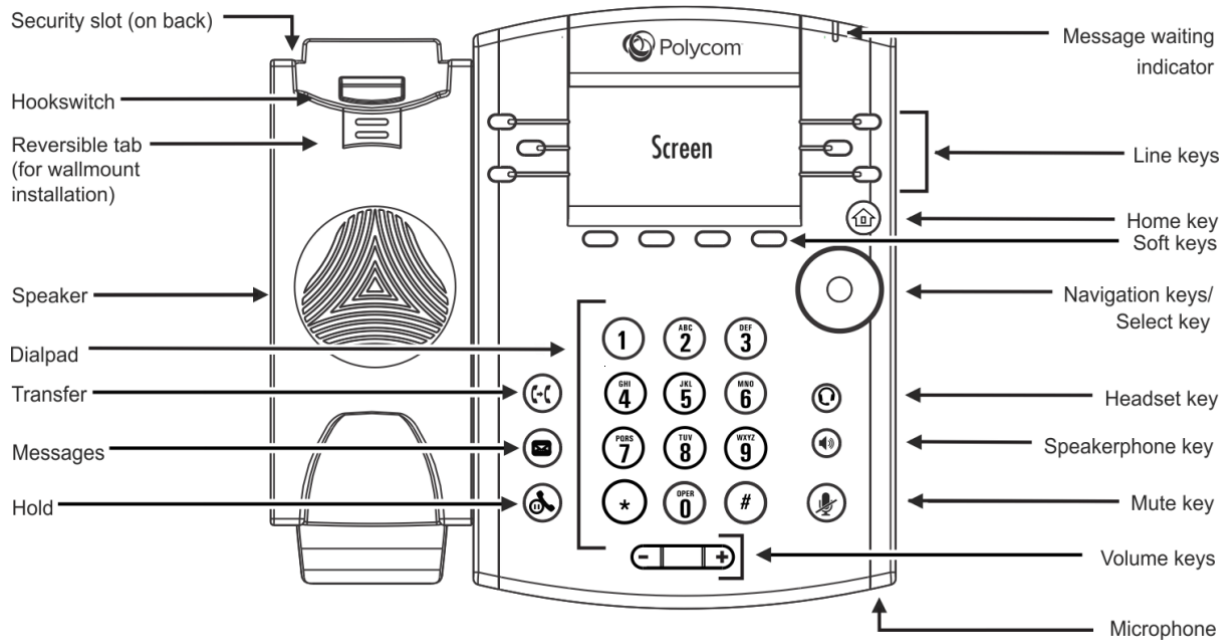

400 VVX Layout

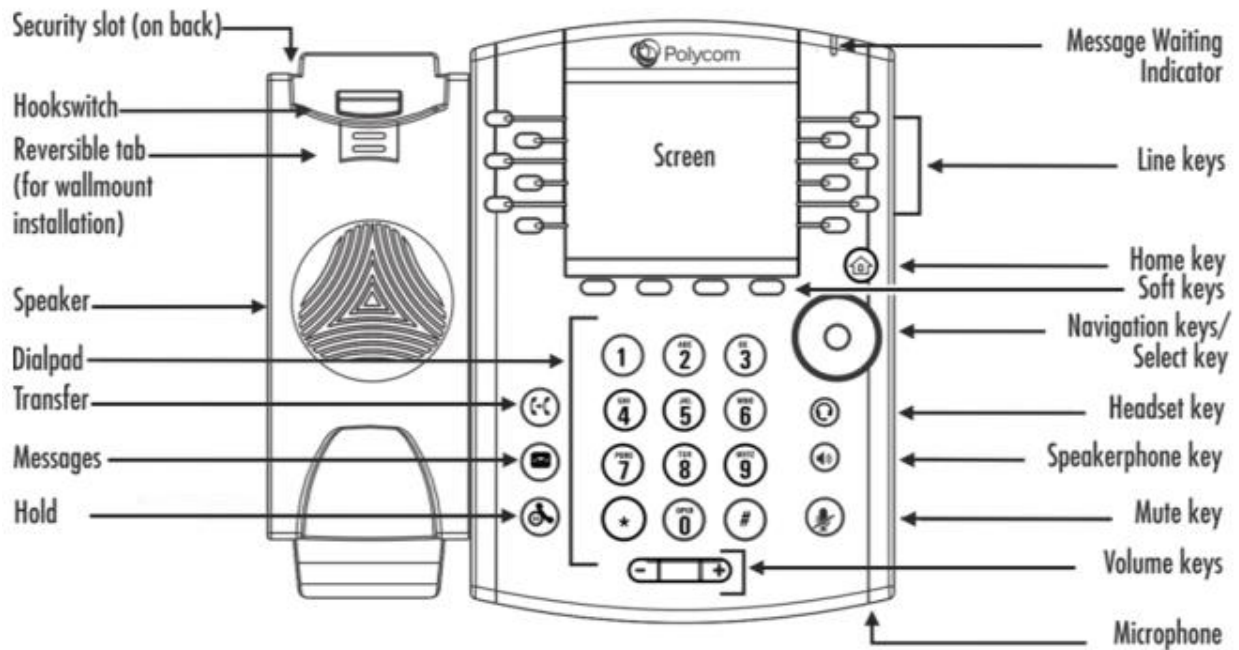

500-600 VVX Layout

